



Ceiling TFG

Ceiling unit coolers

Application

Series with double air flux, designed for use in working and packaging areas, where it's basic to have low noise level and low air velocity. Typical rooms volume, from 50 to 500 m³. Units designed for an easy maintenance with immediate access to the inspection areas. This series is available as evaporator (DX or pump, HFC, NH₃ e CO₂) and Brine unit cooler.

Standard design

Coil

Coil manufactured from corrugated aluminium fins and copper rippled tubes nominal diameter 12 mm for DX evaporator and smooth tubes nominal diameter 16 mm for brine and NH₃ units.

Casing

It's manufactured from pre-painted aluminium sheets RAL 9010, protected by plastic film, suitable for applications where a high degree of hygiene is required and also for sea environment.

Fans

- Three-phase motor 400V-50HZ, protection class IP 54 according to DIN 40050.
- Integrated thermal protection by thermo contacts.
- Provide reliable protection against thermal overload.

Benefits

- Low noise level
- Easy access and maintenance
- Reliable construction
- Eurovent certificated

Optional

- Wiring to common terminal box IP55
- Re-Heating coil
- Double Insulated drip trays
- Coil coating with three years warranty
- Cataphoresis treatment
- Motor fan 230V/1ph 50Hz
- Stainless steel tube
- Non standard fin spacing
- Stainless steel casing
- Electric defrost
- Low fan speed motor

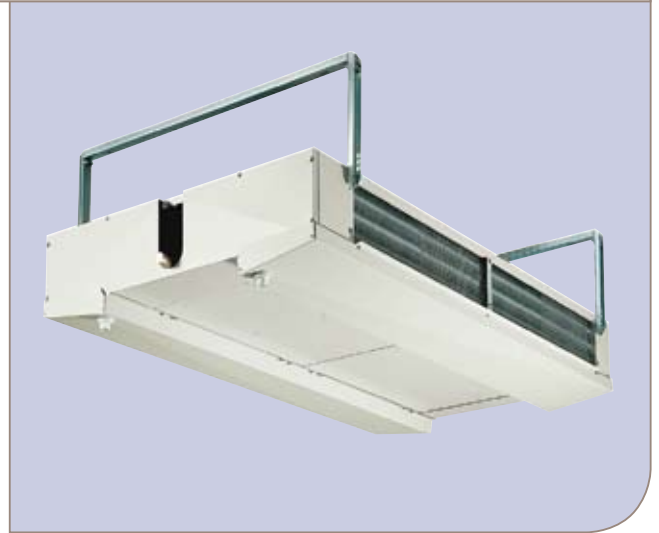

Top fan ceiling - TFG

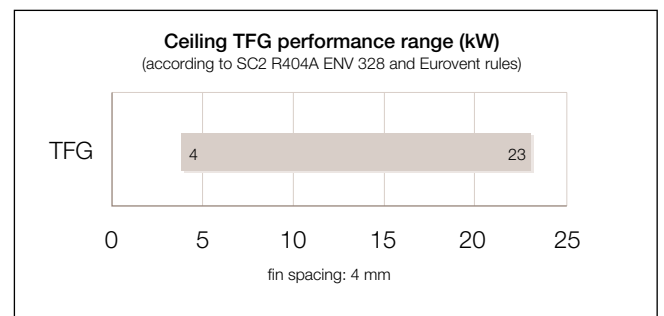

Typical application

Series	Green Line TFG
Product	Fruits and vegetables
Room temperature	12±0°C
Standard fins spacing (mm)	4

TFG W 40 3 A 4 T

- A = single phase, T = three phase
- Fin spacing 4 mm
- Coil size A B
- Number of fans 1, 2, 3, 4, 5
- Fan diameter 40 = 400 mm
- E = direct expansion, A = Ammonia, W = brine unit cooler
- Top Fan Ceiling = TFG

Dimensions (mm)

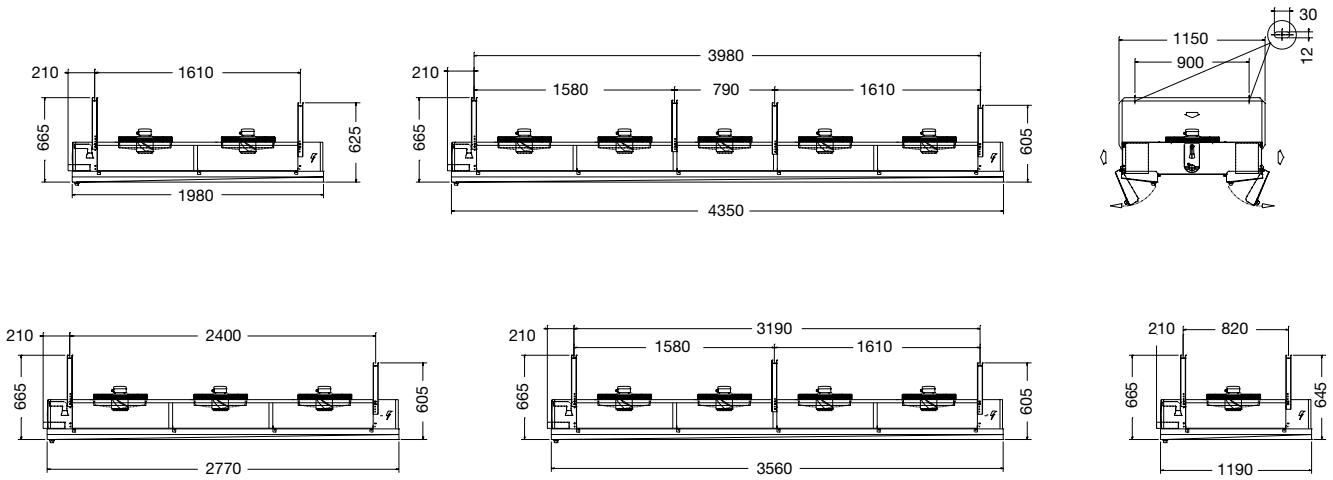

PCT00055EN 0501

All rights reserved for changes in specifications

How to contact Alfa Laval

Up-to-date Alfa Laval contact details for all countries are always available on our website at www.alfalaval.com

